

141



MODEL NO	F1 (N)	F3 (N)	Fi		AÇI (ANGLE) (± 5°)	AĞIRLIK (WEIGHT) (gr ±%2)
			VERİM (YIELD) (F1:Fi)			
141 - 4	1750	2600	4:1		90°	628

F1 : BASKI KUVVETİ (EXERTING FORCE), F3 : TUTMA KAPASİTESİ (HOLDING CAPACITY), Fi : UYGULAMA KUVVETİ (APPLIED FORCE)

Ayak Tipi: Yatay Tabanlı
Body Mounting Base: Horizontal

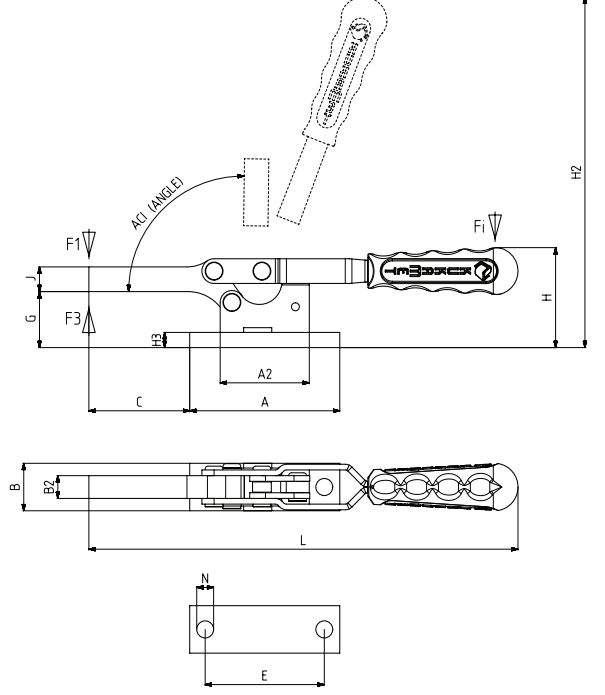

141-L

KİLİTLİ/LOCKED



MODEL NO	A	B	B2	C	E	G	H	H2	H3	J	L	N
141 - 4	80	28	12	53,75	63,5	29,5	53	212	8	13	256	Ø9

142



MODEL NO	F1 (N)	F3 (N)	Fi		AÇI (ANGLE) (± 5°)	AĞIRLIK (WEIGHT) (gr ±%2)
			VERİM (YIELD) (F1:Fi)			
142 - 4	1750	2600	4:1		90°	510

F1 : BASKI KUVVETİ (EXERTING FORCE), F3 : TUTMA KAPASİTESİ (HOLDING CAPACITY), Fi : UYGULAMA KUVVETİ (APPLIED FORCE)

Ayak Tipi: Dikey Tabanlı
Body Mounting Base: Vertical

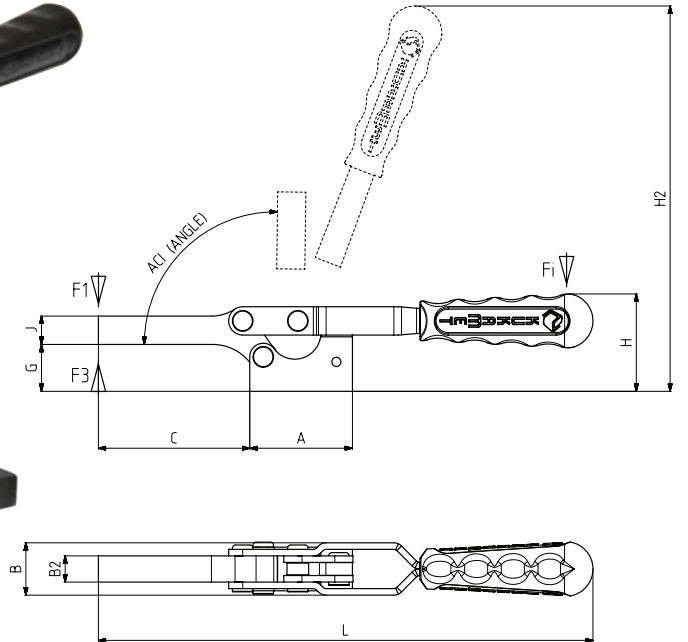

142-L

KİLİTLİ/LOCKED



MODEL NO	A	B	B2	C	G	H	H2	J	L
142 - 4	47,5	28	12	70	21,5	47	202	13	229