

532



MODEL NO	F1 (N)	F3 (N)	Fi	BASKI VİDASI (SQUEEZE SCREW)	STROK	AĞIRLIK (WEIGHT) (gr ±%)
			VERİM (YIELD) (F1:Fi)			
532 - 3 (Ø 12)	2500	3700	16:1	M8X50	38	590
532 - 3 (Ø 14)	2500	4000	16:1	M8X50	38	610
532 - 4 (Ø 16)	4500	8100	23:1	M10X70	47	1030
532 - 4 (Ø 18)	4500	8800	23:1	M10X70	47	1060
532 - 5 (Ø 20)	7500	18450	30:1	M12X80	100	2870

F1 : BASKI KUVVETİ ( EXERTING FORCE ) , F3 : TUTMA KAPASİTESİ ( HOLDING CAPACITY )  
 Fi : UYGULAMA KUVVETİ ( APPLIED FORCE )



### Ayak Tipi: Çatay Tabanlı, Döküm Gövdeli

### Body Mounting Base: Horizontal, Casting

#### Ürün özellikleri ;

Ağır iş uygulamalarında kullanıma uygun mukavemetli ürünlerdir.  
 Gövde mukavemetli GGG-60 döküm malzemeden üretilmiş ve siyah elektro statik toz boya ile boyanmıştır.

Mil, yüksek aşınma direnci ve korozyon direnci için sert krom kaplı malzemeden üretilmiştir.  
 Mekanizma parçaları çelik malzemeden üretilmiş ve korozyon direnci için galvaniz kaplama yapılmıştır.

#### Product Features ;

The products are strong and suited for heavy duty applications.

The body is made of strong GGG-60 casting and coated with black electrostatic powder paint.  
 The rod is made of hard chrome plated steel for high wear and corrosion resistance and the mechanism parts are made of galvanized steel for corrosion resistance.



521

Sayfa/Page: 64



531

Sayfa/Page: 66



536

Sayfa/Page: 73

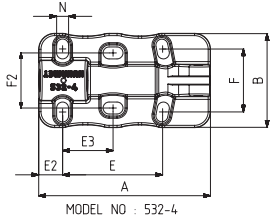
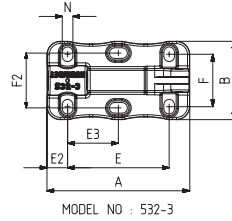
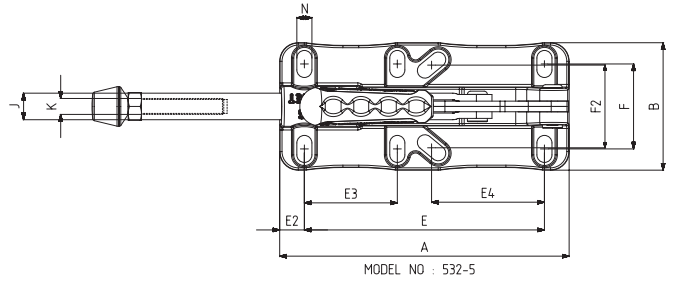
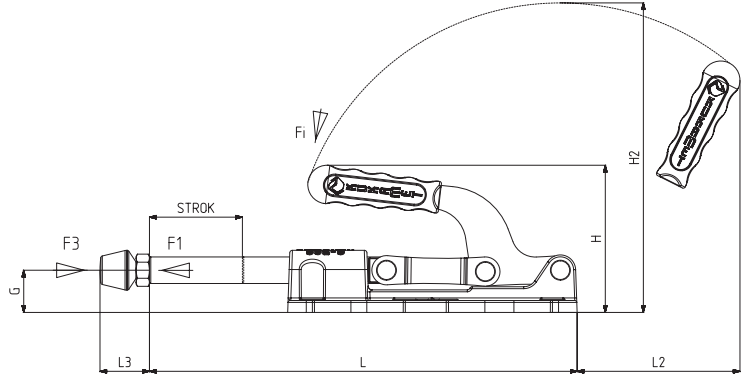

MODEL NO	A	B	E	E2	E3	E4	F	F2	G	H	H2	J	K	L	L2	L3 Min	L3 Max	N
532 - 3 (Ø 12)	107	59	76,5	15,5	38	-	39,5	41	17,5	73	127	12	M8	156	81	24	58	8x11
532 - 3 (Ø 14)	107	59	76,5	15,5	38	-	39,5	41	17,5	73	127	14	M8	156	81	24	58	8x11
532 - 4 (Ø 16)	130	71	75,5	18	38	-	47,5	41,5	20,5	86	159	16	M10	188	94	32	81	9x15
532 - 4 (Ø 18)	130	71	75,5	18	38	-	47,5	41,5	20,5	86	159	18	M10	188	94	32	81	9x15
532 - 5 (Ø 20)	218	96	180,5	18,5	70	85	64	62,5	31,8	111	234	20	M12	322	122	39	94	11x20